

Thank you for your interest in **Little David** Case Sealers by **Loveshaw**. Here is your recently requested pricing for a Model **LD-Xss** semi automatic uniform case sealing machine of "304" grade stainless steel construction and hardware. This machine is specifically designed to excel in wash down environments.

This machine will receive from your operator your uniform size regular slotted corrugated containers with all flaps folded and closed prior to infeed. The case will be processed and 2" wide pressure sensitive tape of commercially good quality will be applied to the top and bottom center seams with leading and trailing tape tabs that are 2-1/4" to 2-1/2" in length on the vertical panels of the case. The case will then be discharged onto your exit conveyor. Bottom belt drive will propel the case through the taping process. The **LD-Xss** that we propose will accept uniform size regular slotted containers within the following dimensions:

	<u>Length</u>	<u>Width</u>	<u>Height</u>
Min:	6"	5-1/2"	4-1/2"
Max:	INF	28"	24"

We propose production speeds of this equipment to be approximately twenty-six (26) containers per minute based on a 24" long case @ 80 feet per minute belt speed. However, throughput speeds of a semi automatic machine can only be determined by operator efficiency and length of time necessary for packing. The delivery of this **LD-Xss** machine can be made in approximately one (1) week from receipt of a firm order. This quotation is valid for 60 days from date issued. Thank you for giving us the opportunity to bid for your business.

Price, FOB, S. Canaan, PA Freight Collect

\$9,960.00

(plus applicable sales, use, privilege or excise taxes and Federal, State or local, if any)

Terms: Net 30 days

Machine Features:

- semi automatic uniform case sealer
- single mast construction
- heavy-duty stainless steel welded tubular design
- non-corrosive / anti-microbial design
- open, easy clean tubular design sheds water
- quick release, endless belts
- self-tracking, drive belt system
- easy access drive motor with electrical quick disconnect
- 2" wide PST (*3" in field conversion capability*)
- right to left case flow (*mirror image in field conversion capability*)
- 22-1/2" conveyor height adjustable up to 28-1/2" (*including leveling pads*)
- 110 volt, single phase electric's
- removable and interchangeable tape cartridges
- TEFC motor
- self centering side rails
- 80 FPM belt speed
- 304 grade stainless steel construction *
- minimized lap joints *
- standoffs (*electrical box*) *
- sealed tubing (*smooth welds & plastic sealed legs*) *
- top UHMW hold down strips (*head skies*)

* designed to AMI specifications (*drive rollers constructed of anodizes aluminum*)

Weight Uncrated:

269 lbs.

Machine Dimensions:

39-7/8" L x 34-3/8" W x 58-1/4" H

Electrical Specifications:

115 V, 1 Ph 60 Hz, 6.4 Amps

Installation:

Installation, training & service will be provided by the local distributor at prevailing rates.

Available Options:

Spare tape cartridge (2" PST)	.CAC60	1,250.00
(3" PST)	.CAC61	1,350.00
3 phase electrical package (any voltage)	----	350.00
Stainless steel top squeezer	.TSA/LDXSS	360.00
Stainless steel infeed pack table (with support)	.ITA/LDXSS/HD	440.00
Stainless steel infeed pack table (roller bed with support)	----	1,270.00
Stainless Steel top 3 flap folder	----	660.00
Stainless steel exit transfer pack table	.ETA/LDXSS	440.00
3" wide PST	----	300.00
Mirror image (left to right case flow)	----	N/C
27-1/2" to 31-1/2" conveyor height	.LPA/EX/LDXSS	345.00
(height includes leveling pads. 32" to 36" height range with casters)		
30-1/2" to 36-1/2" conveyor height	.LPA/EXH/LDXSS	420.00
(height includes leveling pads. 35" to 41" height range with casters)		
NEMA 4X Enclosure, Wiring & switches	----	2,180.00
(includes stainless steel gear reducer & motor)		
Jet printer mounting bracket	.JPM/LDXSS	600.00
(3-3/4" minimum height case with side-rails fully extended)		
NEMA 4 Enclosure, Wiring & switches	----	1,270.00
(includes white epoxy gear reducer & motor)		
Recommended spare parts kit	.SPKT-LDX/60	670.00
(1 set belts, 4 knives, misc. cartridge parts)		
Recommended spare parts kit (3")	.SPKT-LDX/61	720.00
(1 set belts, 4 knives, misc. cartridge parts)		
Stainless steel tape cartridge (2" PST)	.CAC60SS	420.00
(3" PST)	.CAC61SS	520.00
Spare Stainless tape cartridge (2" PST)	.CAC60SS	1,600.00
(3" PST)	.CAC61SS	1,700.00
CF5 connection kit	.CF5CKLDX/SS	500.00
Stainless steel dual locking casters (swivel & rotating)	.LDC/LDXSS	525.00

Special Option Package Price:

Complete 2" machine with NEMA 4 electrical package with white epoxy gear reducer & motor, Stainless Steel Top Squeezer & Stainless Steel Infeed Pack Table 11,010.00

3" PST version 11,410.00



Case Sealer

LD-Xss

Wash Down Case Sealing for the *Real World*

This revolutionary case sealer was designed to excel in the most sanitary sensitive industrial environments.

Little David delivers packaging equipment that works for you

Little David LD-Xss

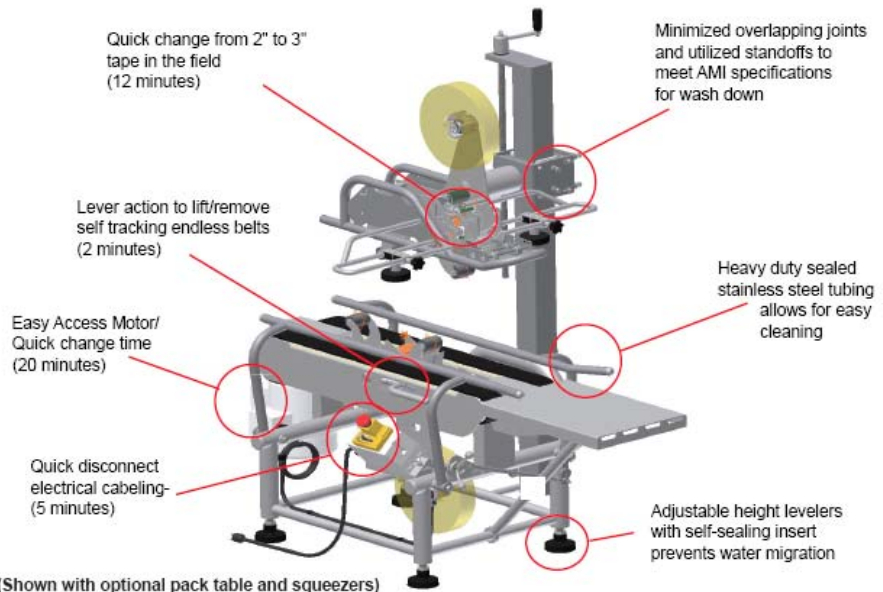

The LD-Xss offers:

- ☑ Heavy duty stainless steel design
- ☑ Fast/easy maintenance
- ☑ Anti-microbial/Easy-clean design
- ☑ Great Value
- ☑ Versatility

The LD-Xss minimizes:

- ☑ Time consuming cleaning
- ☑ Down-time for maintenance
- ☑ Risk of contamination
- ☑ Periodic painting
- ☑ Moving machine

LD-Xss

Dimensions:

LD-Xss:

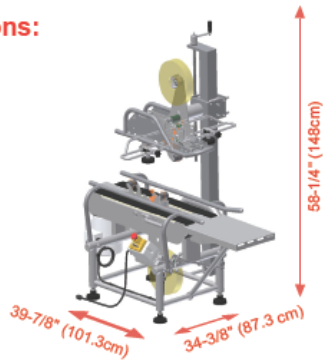

Additional Stainless Steel Solutions:

Also Available LD-16A SS:

- Fully-automatic case sealer
- Seals top and bottom of uniform box sizes

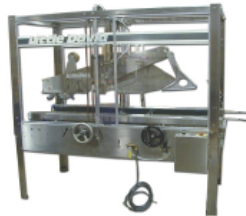

Also Available MicroJet SS:

- All MicroJet models available in stainless steel



Options of the LD-Xss:

- Recommended Spare Parts Kit
- Spare CAC50 Tape Cartridge
- 3 Phase Motor (any voltage)
- Stainless Steel Top Squeezers
- Stainless Steel Front and Rear Pack Tables
- Stainless Steel Casters
- NEMA 4 Wiring-enclosure-switch & motor w/ epoxy gear reducer

Features of the LD-Xss:

Extremely Durable

- Heavy duty stainless steel design
- Continuous TIG welding

Fast/Easy Maintenance

- Patent pending quick release drive belts
- Easy access motor mounts for fast changeover

Anti-Microbial/Easy-Clean Design

- Maximized water shedding to prevent bacterial growth
- Minimal overlapping joints to meet AMI standards for wash down environments
- Sealed tubular construction promotes easy cleaning

Versatility

- 2" to 3" changeover in field
- Mirror image changeover in field

Reliable Performance - Warranty

- 1 Year all components*
- 2 Years Gear Reducer
- 3 Years Cartridge*

*Moving and wear parts are not included. Other restrictions may apply. Consult Loveshaw or your authorized Little David® Distributor for details

Specifications of the LD-Xss:

Power Requirements:

- 110 Volts, 60 cycle, single phase
- Note: Other voltages available. Contact Loveshaw for details.

Operating Speed:

- Continuous belt drive; 80' per minute (24.4 m/min.)
(production rate depends on box size and operator dexterity)

Closure Material:

- Pressure sensitive tape

Weight:

- 269 Lbs. uncrated

Case Capacity:

Length: 4-1/2" - infinite

Width: 5-1/2" - 28"

Height: 4-1/2" - 24"

Note: Certain length x width x height combinations may not process due to unstable conveying conditions.

LOVESHAW

an ITW Company

Route 296, Box 83
South Canaan, PA 18459
Tel: (570) 937-4921 Fax: (570) 937-3229
(800) 572-3434

LOVESHAW Europe

A Division of ITW Ltd.

Unit 9 Brunel Gate,
West Portway Industrial Estate
Andover, Hampshire England SP 10 3 SL
Tel: (1264) 357511 Fax: (1264) 355964



©Loveshaw, an ITW Company, 2007