

FOX C4 QUOTATION

OPTIONS

- Scale Package - **\$3700**
- Dual Turntable - **\$4200**

FREIGHT IS F.O.B. FACTORY

CONTROL FEATURES

- Programmable Key Pad Controls
- LCD Display Screen (providing function control viewing)
- Variable Turntable Speed 0-15 RPM
- Variable Film Carriage Speed Up/Down Control
- Separate Top/Bottom Wrap Selectors 1-9
- Separate Film Height Selector 1-9"
- Flush Mounted Control Panel (built into tower)
- Cycle Counter
- Manual Carriage Raise/Lower Control
- Turntable Jog with Auto Home Alignment
- Large Emergency push button power On / Off Switch with indicator light
- Start Cycle Push Button
- Standard Wrap Up/Down Program
- 12 Volt DC Control System (for operator safety)
- All circuits protected by fuses (easy access)
- 20 amp Power Board Circuits to carry a 10 amp load

TECHNICAL INFORMATION

- All switches, relays, SCR controls are available locally throughout North America
- Power Requirements: 115 VAC @ 15 Amps, 60 Hz
- Complete manual with electrical schematic provided with machine

TURNTABLE DRIVE

- Positive home alignment
- 0 -15 RPM turntable speed
- 1/2 HP SCR variable speed drive
- Adjustable electronic soft start / stop

Provided by: www.PTIPackaging.com

Toll Free 1-800-472-0067 or
info@ptipackaging.com

Price: \$7,889.00

ON SALE NOW!

Control Panel Face



STRUCTURAL FEATURES

- Heavy Duty 3/8" turntable plate
Fork Lift portable from front or rear
- Large formed steel tower
5/16" thick base plate
Rigid uni-body base frame construction

CARRIAGE LIFT

- V Groove wheel supports providing effortless movement and maximum stability (Qty4)
- Heavy duty ANSI #50 chain carriage lift
- 1/2 HP DC SCR variable speed drive
- Carriage chain fully guarded

FILM DELIVERY

- FOX "Linear" 20-inch powered pre-stretch film delivery system
- Easy thread film carriage
- No hinges, latches or idler rollers to wear and cause inconsistent film stretching
- Electronic film force control on film carriage
- Adjustable mechanical force to load
- Sensor switch film feed speed control
- 1/2 HP DC SCR variable speed film drive
- Pre-stretch 50-300% upon request (200% standard settings)
- Triple beam auto height eye capable of recognizing all colors including black

-S-pattern film feed film carriage.

• "S" pattern film threading: why?

1/ The film wraps around the pre-stretch rolls 300 degrees prevents slippage

2/ "W" pattern requires many more roller to hold the film from slipping. Wear on rollers within 6 months will reduce pre-stretch or create no pre-stretch

3/ "W" pattern carriages are prone to film wrapping on the rollers, requiring knives to be used to remove it.

4/ "W" pattern film carriage have as many as 8 rollers to wear. Fox has 3 rollers creating a simply and better wear film carriage.

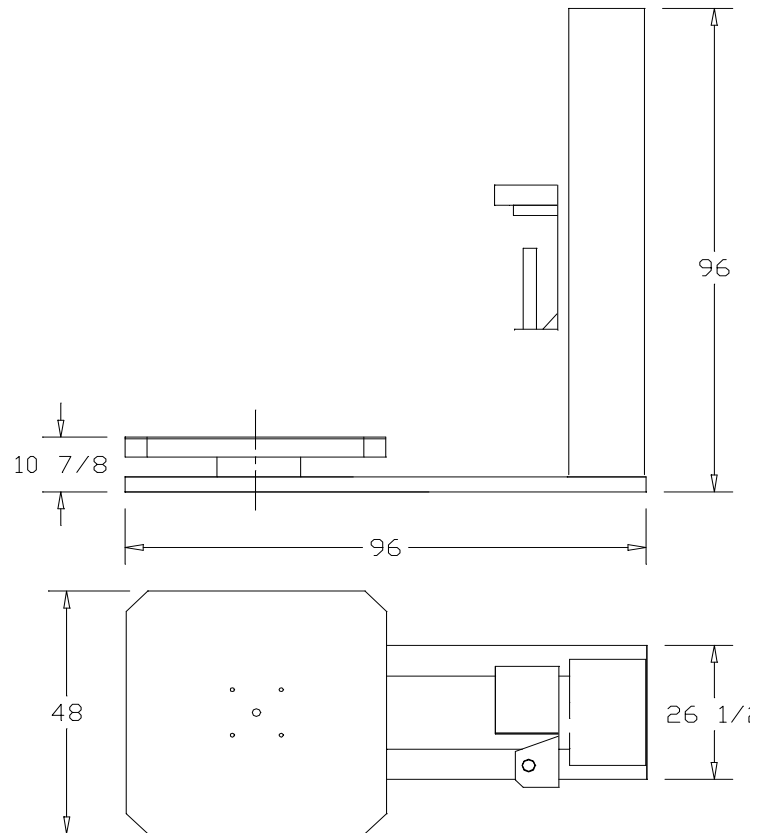

Fox Packaging Services wrappers are warranted against parts defects for a period of three (3) year, and three (5) years on workmanship if installed, maintained and used in accordance with factory specifications. Normal wear parts are no covered under this warranty. Normal wear parts are: Chains, UHMW clamp slides, film cutter wire and fuses or breakers.

Fox Packaging is not responsible for any labor costs incurred in the replacement of any defective or damaged parts

Defective parts that have been disassembled, damaged during removal or modified in any way by unauthorized personnel will void the warranty. Damage caused by inadequate voltage supply, normal wear, misuse or neglect, is not covered by this warranty. Fox Packaging Services shall under no circumstance be liable for any consequential damages, losses or expenses arising in connection with the use of, or inability to use our equipment, for any purpose whatsoever.

Fox Packaging Services makes no warranty as to the fitness of the equipment for a particular purpose, except as stated herein. Fox Packaging Services makes no other warranty, expressed or implied, statutory or otherwise. Neither does Fox neither assume nor authorize anyone else to assume for it any other obligation relating to Fox Packaging Services machinery or equipment. Fox Packaging Services sole obligation under this warranty will be to provide replacement parts, ex-works Scarborough, Ontario point of shipment.

Fox Packaging Services does not warranty any machine that is used in out-door applications and will not be liable for any damage that may occur to the equipment. This includes all products produced by Fox Packaging Services.

Fox Packaging will not be liable for any claims of liability relating to improper operating conditions.

This warranty is in lieu of other warranties, expressed or implied, statutory or otherwise. All implied warranties, including but not limited to the implied warranties of merchantability and fitness for a particular purpose are hereby excluded.

The above clearly states Fox Packaging Services is the warrantor, not the distributor, and it disallows the distributor from Fimposing warranty or liability obligations on Fox Packaging Services.

This warranty is considered void if any Fox Packaging machinery is operated outdoors and exposed to the elements.

ox Packaging Services will not be responsible for any claims of liability relating to improper operating conditions.

CONTRACTUAL CLAUSE

- 1) *Until such times as the purchase price and all interest thereon and costs and charges payable under this agreement are paid in full and all other terms and conditions of this agreement have been satisfied, title to the goods shall remain vested in the seller.*
- 2) *The reservation of title provided in subsection (1) constitutes a purchase money security interest securing the punctual payment of all amounts payable under this agreement and the performance of all other obligations of the purchase under this agreement.*
- 3) *Until the occurrence of an act or event of default, the purchaser may have possession of and use the goods in any lawful manner consistent with the agreement.*
- 4) *Where the goods are repaired or additions, modifications or other alterations are made to any of the goods, all property and rights in any replacement parts or other good that becomes attached to the goods purchased shall be vested in the*
- 5) ***All order are considered final and any order cancelled for any reason shall be subject to a 25% restocking cost of suggested resale price and will be applied without negation***